

PN: LE18134

TECHNICAL SPECIFICATIONS

D-Ring Extender 18 in.

18 in. D-ring extender, 3/4" snap hook on one end and large D-ring on opposite end.

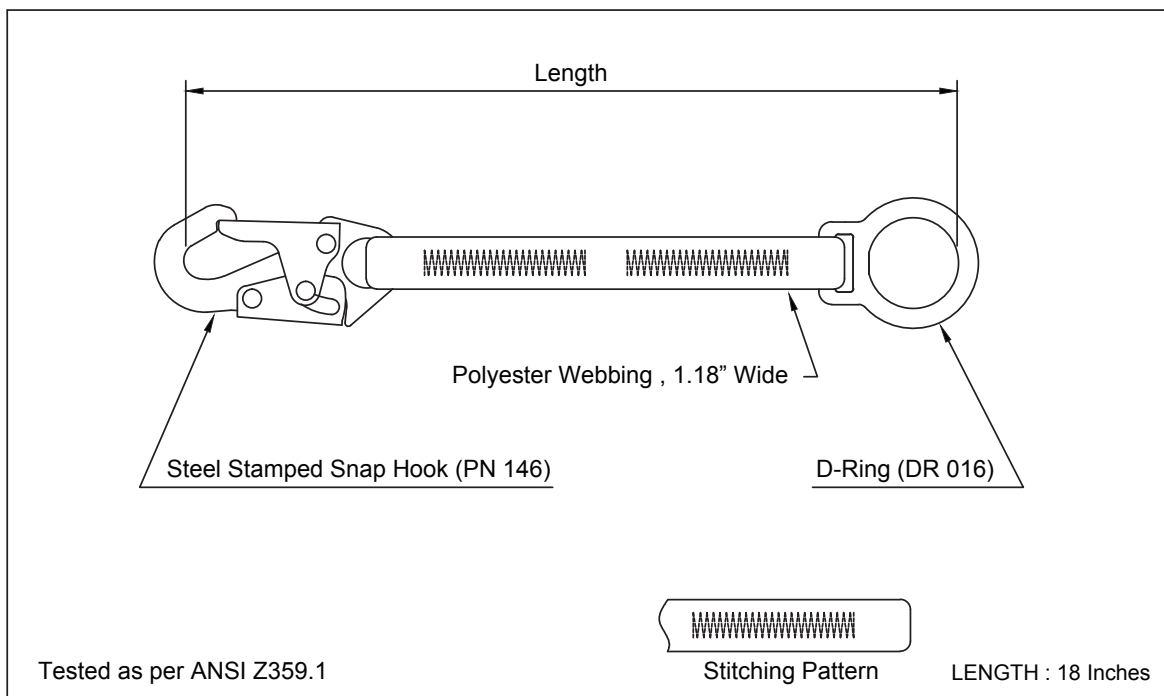

DESIGN: 1.18 in. wide polyester webbing having steel stamped snap hook at one end and D-ring at other end.

WEBBING: Material: Polyester
Width: 1.18 in. \pm 0.04 in.
Breaking Strength: 6000 lbs.

STITCHING THREAD: Material: High-tenacity polyester

METAL COMPONENT: Material: Alloy Steel
Plating: Zinc plated
Finish: Shot blasted
Breaking Strength: 5000 lbs.

VITAL TEST COMPLIANCE: Static Strength: 5000 lbs. for 1 minute

WEIGHT: 1.21 lbs. \pm 0.02 lbs.