

PN: CS817

TECHNICAL SPECIFICATIONS

Confined Space Winch

Confined Space Winch, galvanized cable, 3/4" hook. Max load 300 lbs. Personal or material. Meets or Exceeds ANSI Z359.1-1992, ANSI Z117. 1-1995.

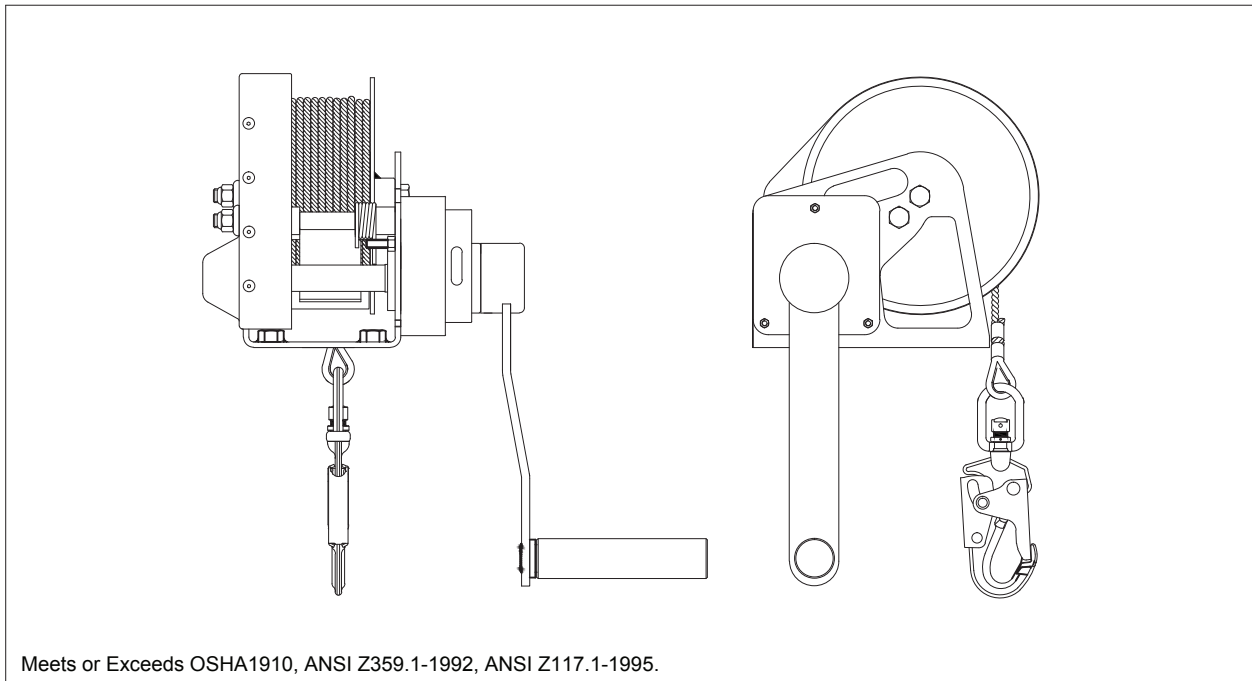

- Material or man lifting rescue winch.
 - Mounting plate having four bolts for mounting to Davit Arm with use of specialized brackets.
- DESIGN:**
- Galvanized steel wire rope of 3/16" & length of 60' maximum.
 - Equipped with Swivel Steel Snap Hook (PN 144 as per ANSI Z359.12-2009 gate strength 3600 lbs.) as connector.
 - Handle rotating mechanism for lifting or lowering.

BODY: Material: Galvanized steel

RATED LOAD CAPACITY: 300 lbs.

VITAL TEST COMPLIANCE: Static Strength: Tested at 3100 lbs.

WEIGHT: 20.61 lbs. ± 0.02 lbs.