

DESCRIPTION

Palmer Safety 5,000-lbf / 22kN Swivel Anchor.
Weighing only 386g (.85-lbs) the Swivel Anchor can be installed on concrete and steel structures with a variety of installation kits available to suit your application.

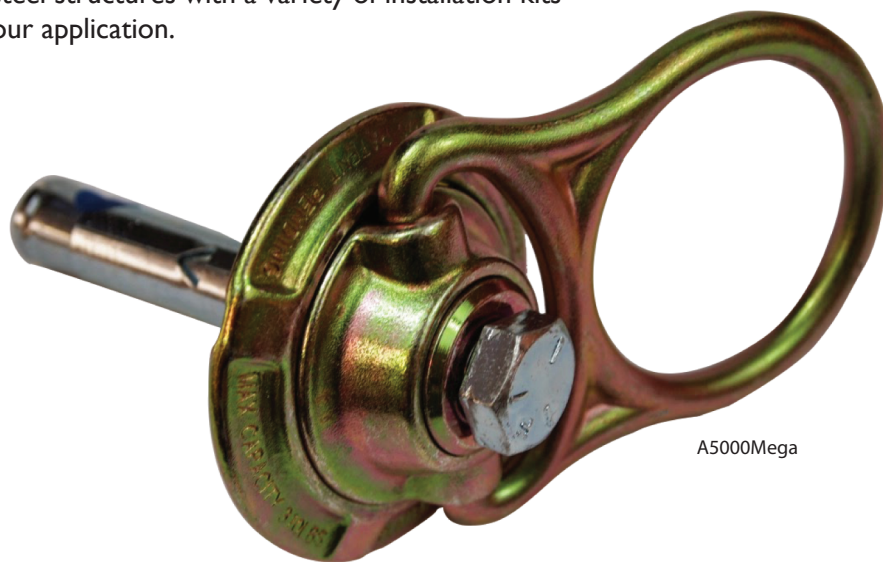

A5000Mega

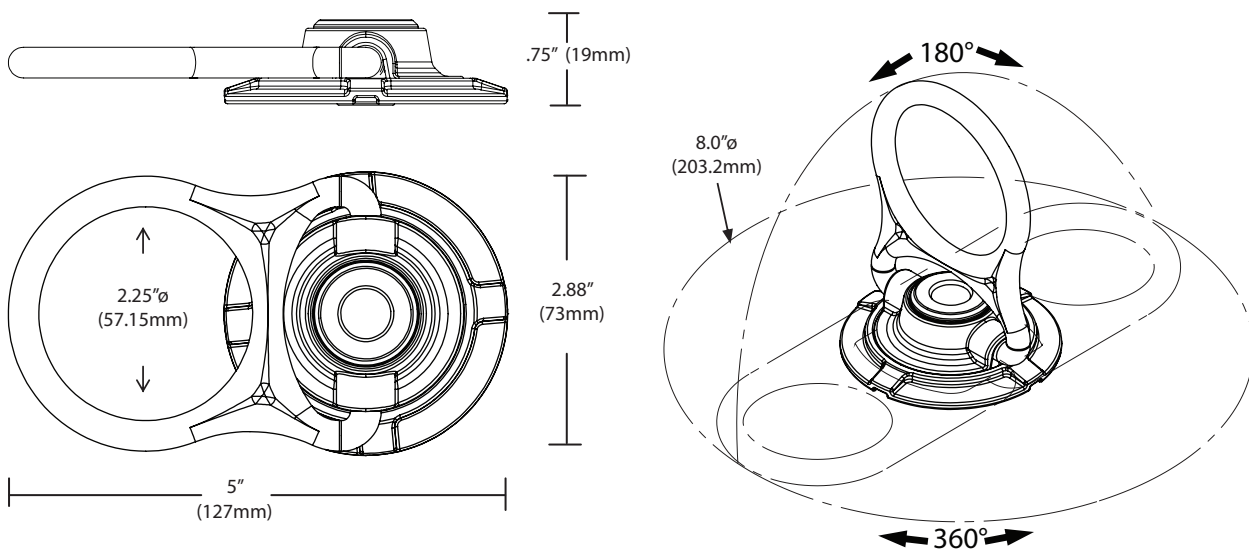

SPECIFICATIONS

- ▲ **UTS**
5,000-lbf / 22kN
- ▲ **Max User Weight**
310-lbs / 140kg
- ▲ **Working Load**
1000-lbs / 454kg

MATERIALS

- ▲ **Swivel**
Zinc Plated Steel

PRODUCT CONFIGURATIONS

MODEL	APPLICATION	COLOR	LOADING	WEIGHT
A5000Mega	Concrete Mounting	Gold Zinc	5,000-lbf (22kN)	530g