

TECHNICAL SPECIFICATIONS

Reusable Roof Anchor

Reusable Roof Anchor. Galvanized Steel with stamped D-ring. Min breaking strength 5000 lbs. Meets or Exceeds ANSI Z359.18-2017.

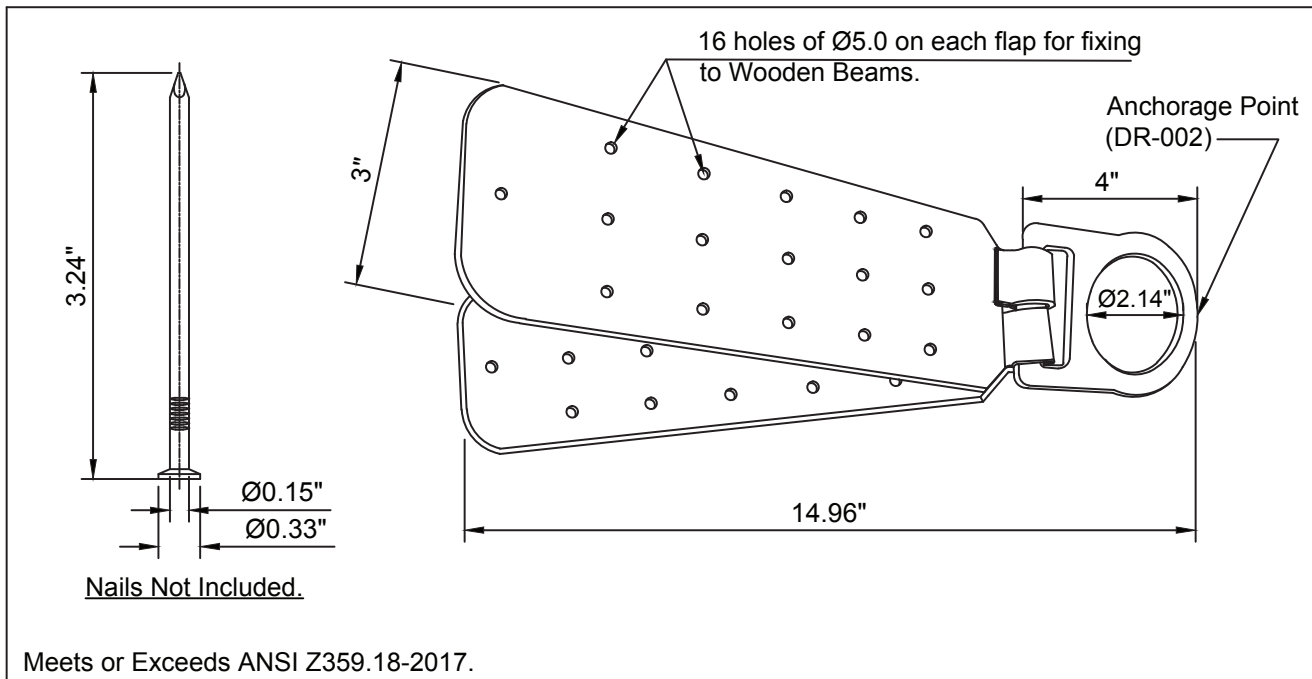

- DESIGN:**
- An ideal anchorage device to be fixed on wooden beams used in roofing.
 - Consists of two steel flaps each having 16 holes which can be fitted on the two sides of a wooden beam by means of nails inserted in the holes.
 - The D-ring can be safely used as an anchor point.

MATERIAL: High strength alloy steel

FINISH: Powder coated or Zinc plated

MINIMUM BREAKING STRENGTH: 5000 lbs.

WEIGHT: 2.39 lbs. ± 0.02 lbs.