

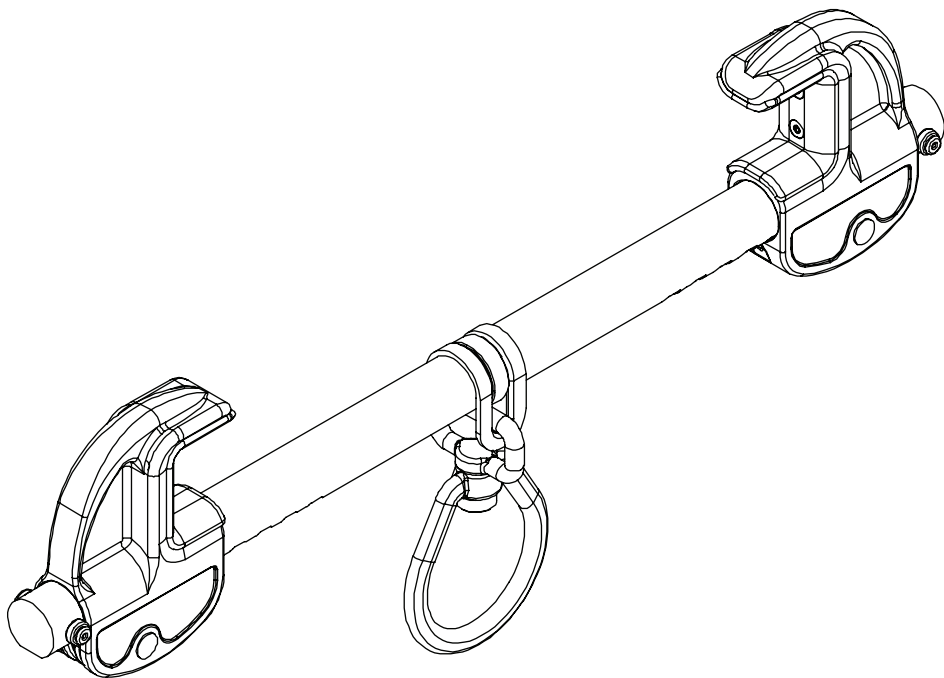

PALMER SAFETY

• Fall Protection • Competent Training • Netting • PPE



SUPER SLIDER BEAM ANCHOR ADJUSTABLE FROM 3.5"-12" Model # A3145000



WARNING: ALL PERSONS USING THIS EQUIPMENT MUST READ AND UNDERSTAND ALL INSTRUCTIONS. FAILURE TO DO SO MAY RESULT IN SERIOUS INJURY OR DEATH. USERS SHOULD BE FAMILIAR WITH PERTINENT REGULATIONS GOVERNING THIS EQUIPMENT. ALL INDIVIDUALS WHO USE THIS PRODUCT MUST BE PROPERLY INSTRUCTED ON HOW TO USE THE DEVICE. AVOID CONTACT WITH PHYSICAL HAZARDS (THERMAL, CHEMICAL, ELECTRICAL, ETC.). MAKE ONLY COMPATIBLE CONNECTIONS.

Read This Instruction Manual Carefully Before Using This Equipment.

User Instructions must always be available to the user and are not to be removed except by the user of this equipment. For proper use, see supervisor, User Instructions, or contact the manufacturer.



WARNING

Compliant fall protection and emergency rescue systems help prevent serious injury during fall arrest. Users and purchasers of this equipment must read and understand the User Instructions provided for correct use and care of this product. All users of this equipment must understand the instructions, operation, limitations and consequences of improper use of this equipment and be properly trained prior to use in accordance with applicable standards. All references to “applicable standards” refer to ANSI, OSHA, state, local, and/or federal standards that apply to approved use.

Misuse or failure to follow warnings and instructions may result in serious personal injury or death.

PURPOSE

The A3145000 is an anchorage connector designed to function as an interface between the anchorage and a fall protection, work positioning, rope access, or rescue system for the purpose of coupling the system to the anchorage. Any references to “anchorage connector” in this manual include, and apply to, the A3145000.

USE INSTRUCTIONS

1. A user must be of sound mind and body to properly and safely use this equipment in normal and emergency situations. Users must have a physician ensure they are clear of any medical conditions that may affect the proper and safe use of this equipment in normal and emergency situations.
2. Before using a personal fall arrest system, user must be trained in accordance with the requirements of applicable standards in the safe use of the system and its components.
3. Only use with systems that comply with applicable standards. The anchorage must have the strength capable of supporting a static load, applied in the directions permitted by the system, of at least 5,000-lbf (22kN) in the absence of certification.
4. The user shall be equipped with a means of limiting the maximum dynamic forces exerted on the user during the arrest of a fall to a maximum of 8 kN (1800-lbf). In the EU these forces must be limited to 6 kN (1350-lbf).
5. Use of this product must be approved by an engineer or other qualified person (as defined by OSHA 29 CFR 1926.32 (m)) to be compatible with any and all structural & operational characteristics of the selected installation location and system to be connected to this anchorage connector.
6. The anchorage connector must be inspected prior to each use for wear, damage, and other deterioration. If defective components are found the anchorage connector must be immediately removed from service in accordance with applicable standards and the manufacturer’s inspection requirements.
7. The anchorage connector should be positioned in such a way that minimizes the potential for falls and the potential fall distance during use. The complete fall protection system must be planned (including all components, calculating fall clearance, and swing fall) before using.
8. A rescue plan, and the means at hand to implement it, must be in place that provides the prompt rescue of users in the event of a fall, or assures that users are able to rescue themselves.
9. After a fall occurs the anchorage connector must be removed from service and destroyed immediately.

USE LIMITATIONS: The anchorage connector shall not be used outside its limitations, or for any purpose other than that for which it is intended.

1. The anchorage connector is designed for single user, with a capacity up to 310 lbs (140 kg) including clothing, tools, etc.
2. The anchorage connector may be pulled in any direction shown in the LOADING CONDITIONS DIAGRAM.
3. The anchorage connector is designed to be used in temperatures ranging from -40°F to +130°F (-40°C to +54°C).
4. Do not expose the anchorage connector to chemicals or harsh solutions which may have a harmful effect.
5. Do not alter or modify this product in any way.
6. Caution must be taken when using any component of a fall protection, work positioning, rope access, or rescue system near moving machinery, electrical hazards, sharp edges, or abrasive surfaces, as contact may cause equipment failure, personal injury, or death.
7. Do not use/install equipment without proper training by a “competent person” as defined by OSHA 29 CFR 1926.32(f).
8. Do not remove the labeling from this product.
9. Additional requirements and limitations may apply depending on anchorage type and fastening option utilized for installation. All placements must be approved by an engineer or other qualified person.
10. This anchorage connector should not be used as part of a horizontal lifeline system that has not been designed and or approved to be used with 5,000-lbf anchorage connectors.
11. The anchorage connector should only be used as intended (see PURPOSE).

COMPATIBILITY LIMITATIONS

Anchorage connector must only be coupled to compatible connectors. OSHA 29 CFR 1926.502 prohibits snaphooks from being engaged to certain objects unless two requirements are met: it must be a locking type snaphook, and it must be “designed for” making such a connection. “Designed for” means that the manufacturer of the snaphook specifically designed the snaphook to be used to connect to the equipment listed. The following connections must be avoided, because they can result in rollout* when a nonlocking snaphook is used:

- Direct connection of a snaphook to horizontal lifeline.
- Two (or more) snaphooks connected to one D-ring.
- Two snaphooks connected to each other.
- A snaphook connected back on its integral lanyard.
- A snaphook connected to a webbing loop or webbing lanyard.
- Improper dimensions of the D-ring, rebar, or other connection point in relation to the snaphook dimensions that would allow the snaphook keeper to be depressed by a turning motion of the snaphook.

***Rollout: A process by which a snaphook or carabiner unintentionally disengages from another connector or object to which it is coupled. (ANSI Z359.0-2007)**

PERFORMANCE:

Minimum Breaking Strength: 5000-lbf (22kN)
Maximum Capacity: One worker with max weight of 310-lbs when used as a single point anchorage connector for personal fall arrest or restraint system

DIMENSIONS:

Weight: 3.4-lbs
Beam Flange Width Range: 3.5" - 12"
Beam Flange Thickness: .25" to 1.25"

REGULATORY COMPLIANCE:

ANSI Z359.18 Type A, ANSI Z359.7-2019, OSHA 1926.502, OSHA 1910.140,

COMPONENT MATERIALS:

Aluminum: Cross Bar, Clamps
Bronze: Flange Insert
Stainless Steel: D-Ring Bracket
Zinc Plated Steel: D-Ring, Spring, Hardware

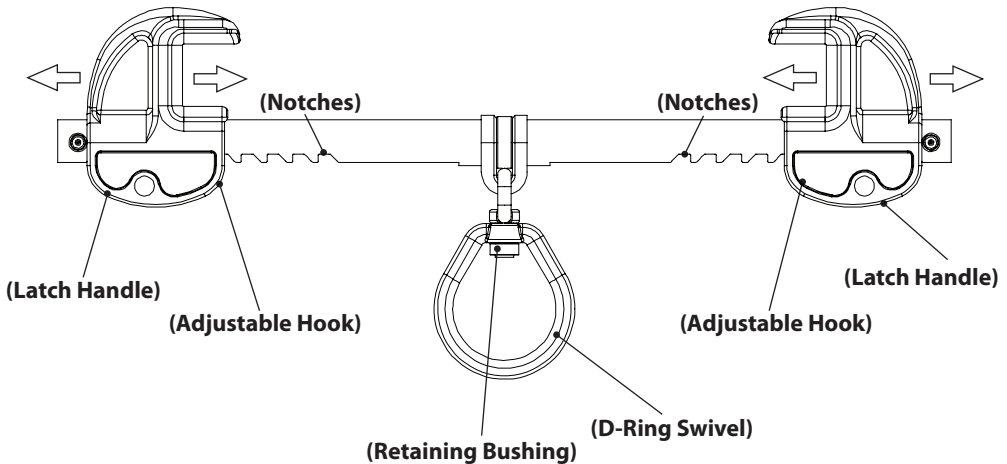
**Installation:**

1. Locate a structural steel beam flange capable of withstanding a 5,000-lbf. static load or meeting OSHA 1926.502 requirements for a safety factor of two.
2. Push in on the latch handle to allow the adjustable hook to move.
3. Keeping the unit perpendicular to the beam, fit the hooks over the edges of the beam flange.
4. Slide the adjustable hook so that both hooks are snug against the beam flange.
5. Pull back the adjustable hook to ensure ratchet teeth are fully seated in the nearest ratchet notches.
6. Tug, rock, and twist the anchor in all directions to ensure that it cannot come off of the flange.

***Always re-adjust according to Installation steps 1-6 when moving to a new or different sized beam.**

****D-ring is centered on the anchorage connector for ease of sliding on beam flanges. Particularly in rope access applications, bodyweight may disengage the centering feature in some loading conditions. This is not a safety concern, but it may affect usability.**

LOADING CONDITIONS DIAGRAM

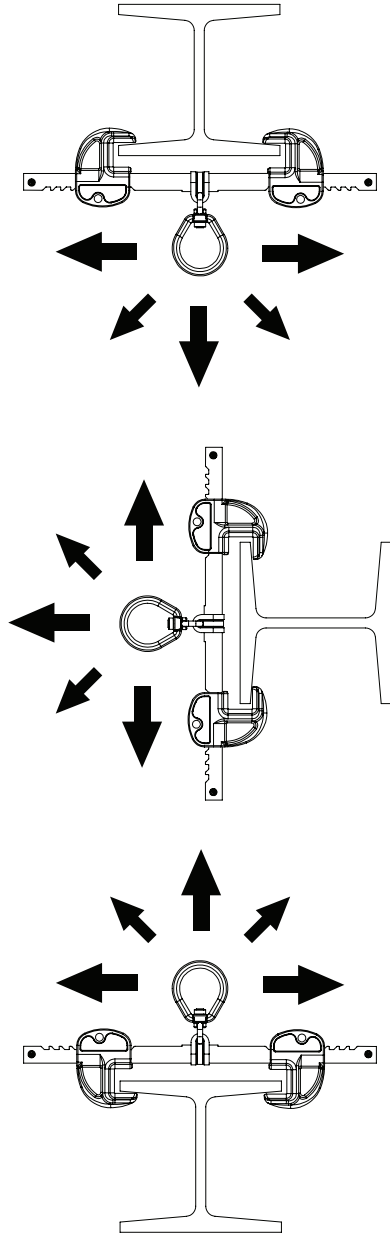

Placement at or below a user's working height requires integration of a compatible ANSI 359.1 shock-absorbing lanyard that does not allow the user to extend more than 6 feet (in any direction) from the anchorage connector before the shock absorber is activated. The beam anchor must be attached to the I-beam flange facing the user (top flange if above, bottom flange if below, etc.).

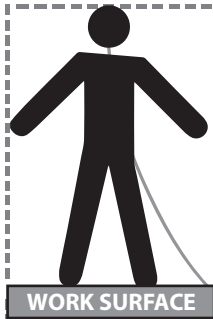

WORK SURFACE

*The user shall be equipped with a means of limiting the maximum dynamic forces exerted on the user during the arrest of a fall to a maximum of 8 kN (1800-lbf). In the EU these forces must be limited to 6 kN (1350-lbf).

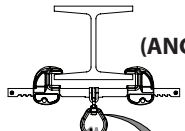

(ANCHOR POINT)

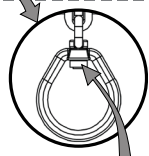

Inspect retaining bushing for wear or damage.



WORK SURFACE

****All products subjected to fall arresting forces should be removed from service immediately!***



MINIMUM CLEARANCE 3ft (1m)
DECK/FLOOR/GROUND LEVEL

WARNING!!! SWING FALLS MAY OCCUR WHEN THE WORKER IS NOT DIRECTLY UNDER ANCHOR POINT.

WARNING LABEL LOCATIONS

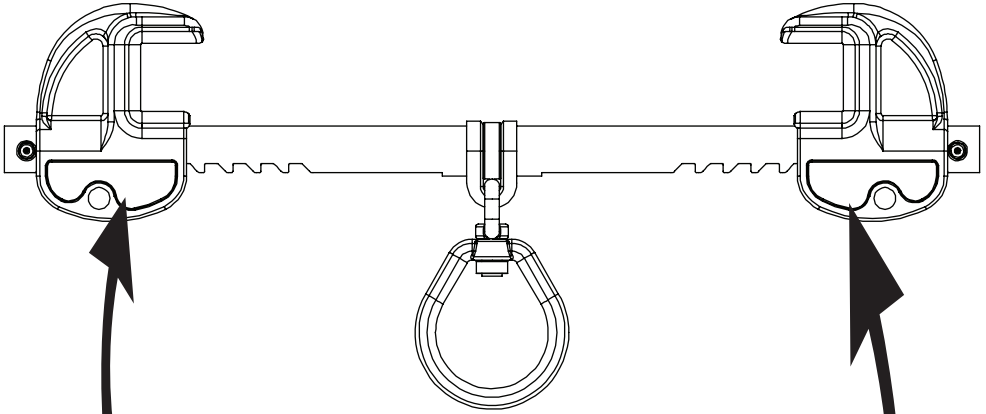

USE ONLY ON STEEL FLANGES THAT CAN SUPPORT AT LEAST 5,000-LBF (22kN)
MAX CAPACITY 310-LBS, MIN BREAKING STRENGTH 5,000-LBF (22kN)

GWP PALMER
STEEL

• Fall Protection • Commercial • Training • Climbing • PPE
Phone: 845-548-5655

Super-Slider

Model: A3145000

MATERIAL: ALUMINUM ALLOY
STAINLESS & ZINC PLATED STEEL

MFD: MM/YYYY
LOT: XXX

DO NOT USE WITH INCOMPATIBLE CONNECTORS. AVOID SHARP EDGES, ABRASIVE SURFACES, THERMAL, ELECTRICAL, AND CHEMICAL SOURCES. REFERENCE INSTRUCTIONS MANUAL SUPPLIED WITH THIS PRODUCT FOR PROPER INSTALLATION PROCEDURES. ALL PERSONS USING THIS EQUIPMENT MUST READ, UNDERSTAND & FOLLOW ALL INSTRUCTIONS FAILURE TO DO SO COULD RESULT IN SERIOUS INJURY OR DEATH

COMPLIANCE

ANSI Z359.18 Type A

ANSI Z359.7 2019

OSHA 1910.140/1926.502



WARNING: It is essential to the safety of the end user that the seller of this device include all instructions pertaining to the proper use, maintenance and inspection of the device in the language of the country in which the product is to be sold.

MAINTENANCE, CLEANING AND STORAGE

Cleaning periodically will prolong the life and proper functioning of the product. The frequency of cleaning should be determined by inspection and by severity of the environment. Clean with compressed air and/or a stiff brush using plain water or a mild soap and water solution. Do not use any corrosive chemicals that could damage the product. Wipe all surfaces with a clean, dry cloth and hang to dry, or use compressed air. When not in use, store anchorage connectors in a cool, dry, clean environment, out of direct sunlight and free of corrosive or other degrading elements.

INSPECTION AND MAINTENANCE LOG

MODEL NUMBER: _____

DATE OF MANUFACTURE: _____

| Date | Part Number | Comments | Inspector Name |
|------|-------------|----------|----------------|
| | | | |
| | | | |
| | | | |
| | | | |
| | | | |
| | | | |
| | | | |
| | | | |
| | | | |
| | | | |

Inspection:

Official periodic inspection must be made at least annually. The inspection must be performed by a qualified person other than the intended user. If severe weather or conditions exist, inspections must be carried out more frequently. All inspection results must be logged in the space provided above. It is recommended that the anchor device is marked with the date of the next or last inspection.

1. Make sure all labeling is affixed to the unit.
2. Inspect anchoring system for signs of damage or wear.
3. Make sure the ring is free to swivel and pivot.
4. Check for excessive play and wear on the retaining bushing
(Bushing should not wiggle or rotate.)
5. Ensure latches engage and disengage properly.
6. Record inspection results in the space provided above.

***If any damage that could affect the strength or operation of the device, or unsafe conditions are found, proper disposal is required. The anchorage connector must be rendered unusable and then properly discarded.**

Product Warranty, Limited Remedy and Limitation of Liability

WARRANTY: THE FOLLOWING IS MADE IN LIEU OF ALL WARRANTIES OR CONDITIONS, EXPRESS OR IMPLIED, INCLUDING THE IMPLIED WARRANTIES OR CONDITIONS OF MERCHANTABILITY OR FITNESS FOR A PARTICULAR PURPOSE. Equipment offered by Palmer Safety is warranted against factory defects in workmanship and materials for a period of one year from date of purchase or first use by the original owner.

LIMITED REMEDY: Upon notice in writing, Palmer Safety will repair or replace all defective items at Palmer Safety's sole discretion. Palmer Safety reserves the right to require that the defective item be returned to its plant for inspection before determining the appropriate course of action. Warranty does not cover equipment damage resulting from wear, abuse, damage in transit, failure to maintain the product or other damage beyond the control of Palmer Safety. Palmer Safety shall be the sole judge of product condition and warranty options. This warranty applies only to original purchaser and is the only warranty applicable to this product. Please contact Palmer Safety technical service department for assistance.

LIMITATION OF LIABILITY: IN NO EVENT WILL PALMER SAFETY BE LIABLE FOR ANY INDIRECT, INCIDENTAL, SPECIAL OR CONSEQUENTIAL DAMAGES INCLUDING, BUT NOT LIMITED TO LOSS OF PROFITS, IN ANY WAY RELATED TO THE PRODUCTS REGARDLESS OF THE LEGAL THEORY ASSERTED.

**Palmer Safety, LLC.
6000 Jefferson Highway
Harahan, LA 70123
Phone: (504) 733-1808 / www.PalmerSafetyUS.com**